

Electric Stacker 1.2t

ES12-12ES/ES12-25DM/ES12-12MM/ES12-25MM

Distinguishing mark							
1.1	Manufacturer			EP	EP	EP	EP
1.2	Model designation			ES12-12ES	ES12-12MM	ES12-25DM	ES12-25MM
1.3	Drive unit			electrics	electrics	electrics	electrics
1.4	Operator type			pedestrian	pedestrian	pedestrian	pedestrian
1.5	rated capacity	Q	kg	1200	1200	1200	1200
1.6	Load center distance	c	mm	600	600	600	600
1.8	Load distance, centre of drive axle to fork	x	mm	795	805	845	850
1.9	Wheelbase	y	mm	1240	1126	1290	1210
Weight							
2.1	Service weight (include battery)		kg	661	462	676	543
2.2	Axle loading, laden driving side/loading side		kg	845/1016	741/921	837/1039	783/960
2.3	Axle loading, unladen driving side/loading side		kg	536/125	343/119	549 / 127	420 / 123
Types,Chassis							
3.1	Tyre type Driving wheels/Loading wheels			PU/ PU	PU/ PU	PU/ PU	PU/ PU
3.2	Tyre size, driving wheels (diameter×width)		mm	Ø210×70	Φ210×70	Ø210×70	Φ210×70
3.3	Tyre size, loading wheels (diameter×width)		mm	Ø80×60	Φ80×60	Ø100×50	Φ100×50
3.4	Tyre size, caster wheels (diameter×width)		mm	Ø130×55	Φ130×55	Ø100×50	Φ100×50
3.5	Wheels, number driving, caster/loading (x=drive wheels)		mm	1x +1/4	1x+ 1/ 4	1x +1/4	1x+ 1/ 4
3.6	Track width, front,driving side	b ₁₀	mm	533	533	533	533
3.7	Track width, rear, loading side	b ₁₁	mm	400	380	1060/1160/ 1260 /1360	1060/1160/ 1260 /1360
Dimensions							
4.1	Tilt of mast/fork carriage forward/backward	α/ β	°				
4.2	Height, mast lowered	h ₁	mm	2056	1940	2086	1940
4.3	Free lift	h ₂	mm		1505		1407
4.4	Lift height	h ₃	mm	2930	1520	2930	1520
4.5	Height, mast extended	h ₄	mm	3487	1971	3895	2053
4.6	Initial lift	h ₅	mm				
4.9	Height drawbar in driving position min./max.	h ₁₄	mm	860/ 1200	860/ 1200	860/ 1200	860/ 1200
4.10	Height of wheel arms	h ₈	mm				100
4.15	Lowered height	h ₁₃	mm	88	88	60	60
4.19	Overall length	l ₁	mm	1740	1615	1650	1570
4.20	Length to face of forks	l ₂	mm	590	465	580	500
4.21	Overall width	b ₁ / b ₂	mm	800	800	1135/1235/ 1335 /1435	1135/1235/ 1335 /1435
4.22	Fork dimensions	s/ e/ l	mm	60/ 170/ 1150	60/ 170/ 1150	35/ 100/ 1070	35/ 100/ 1070
4.24	Fork carriage width	b ₃	mm	680	680	800	780
4.25	Outside width of the forks	b ₅	mm	570	550	200~765	200~765
4.26	Distance between wheel arms	b ₄	mm			100	100
4.31	Ground clearance, laden, below mast	m ₁	mm				
4.32	Ground clearance, center of wheelbase	m ₂	mm	30	30	40	40
4.34.1	Aisle width for pallets 1000 × 1200 crossways	Ast	mm	2225	2137	2255	2175
4.34.2	Aisle width for pallets 800 × 1200 lengthways	Ast	mm	2150	2062	2180	2100
4.35	Turning radius	Wa	mm	1408	1295	1404	1329
Performance data							
5.1	Travel speed, laden/ unladen		km/ h	4/4.5	4/4.5	4/4.5	4/4.5
5.2	Lifting speed, laden/ unladen		m/ s	0.12/0.22	0.12/ 0.22	0.12/0.22	0.12/ 0.22
5.3	Lowering speed, laden/ unladen		m/ s	0.12/0.11	0.12/ 0.11	0.12/0.11	0.12/ 0.11
5.8	Max. gradeability, laden/unladen		%	3/10	3/ 10	3/10	3/ 10
5.10	Service brake type			Electromagnetic	Electromagnetic	Electromagnetic	Electromagnetic
Electric-engine							
6.1	Drive motor rating S2 60 min		kW	0.65	0.65	0.65	0.65
6.2	Lift motor rating at S3 15%		kW	2.2	2.2	2.2	2.2
6.3	The maximum allowed size battery		mm	325x180x230	270x180x230	325x180x230	270x180x230
6.4	Battery voltage/nominal capacity K20		V/ Ah	2x12/105	2x12/85	2x12/105	2x12/85
6.5	Battery weight		kg	2x30	2x25	2x30	2x25
Addition data							
8.1	Type of drive unit			DC	DC	DC	DC
10.5	Steering type			Mechanical	Mechanical	Mechanical	Mechanical
10.7	Sound pressure level at the driver's ear		dB(A)	74	74	74	74

If there are improvements of technical parameters or configurations, no further notice will be given.
The diagram shown may contain non-standard configurations.

ES10-10MM/ES10-22MM/ES12-12MM/ES12-25MM

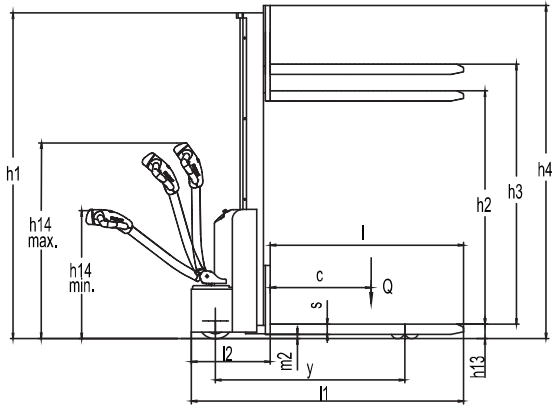

ES10-10MM/ES12-12MM

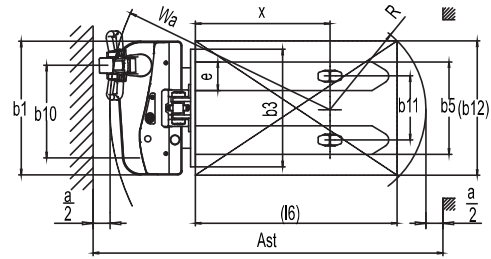

ES10-22MM/ES12-25MM

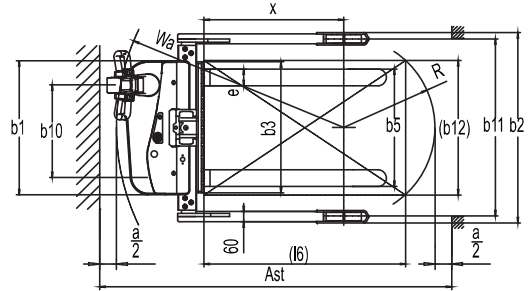

ES10-10ES/ES10-22DM/ES12-12ES/ES12-25DM

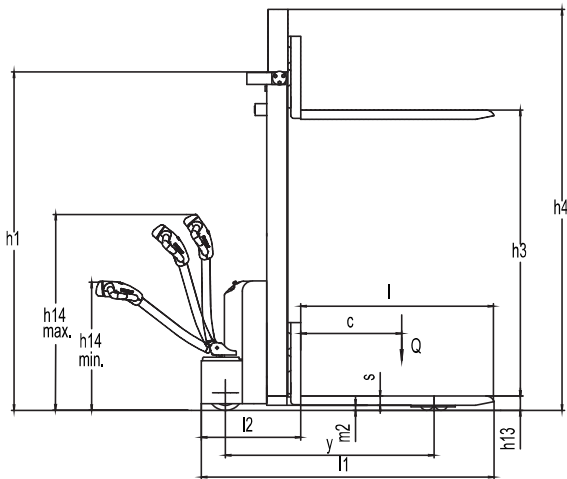

ES10-10ES/ES12-12ES

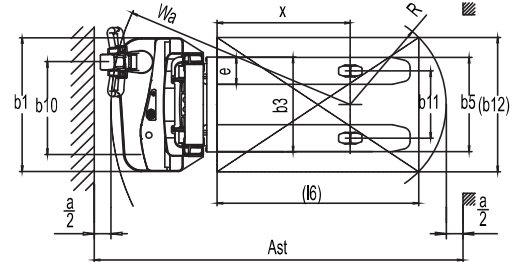

ES10-22DM/ES12-25DM

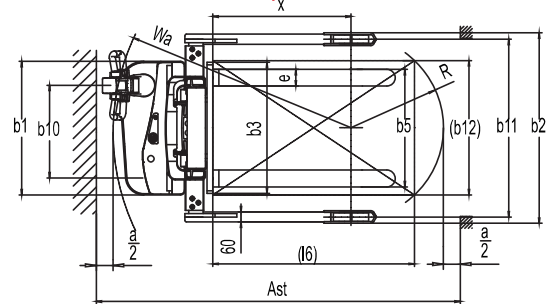

RATED CAPACITIES GRAPH

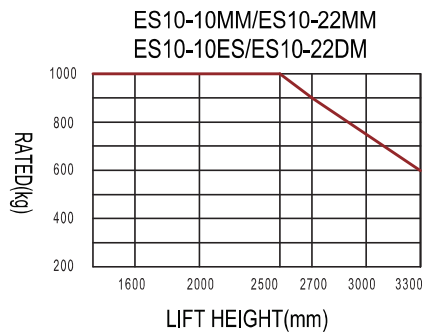

RATED CAPACITIES GRAPH



Mast Option

ES10-10ES

mast types	Lift h3+h13 (mm)	Lowered mast height h1 (mm)	Free lift h2 (mm)	Extended mast height h4 (mm)
Duplex ZT	2515	1772	—	2987
	2715	1872	—	3187
	3015	2022	—	3487
	3315	2172	—	3787

ES12-12ES

mast types	Lift h3+h13 (mm)	Lowered mast height h1 (mm)	Free lift h2 (mm)	Extended mast height h4 (mm)
Duplex ZT	1205	1575	1120	1575
	1405	1775	1320	1775
	1605	1975	1520	1975
	1705	2075	1705	2075
	2515	1802	—	3021
	2715	1902	—	3221
	3015	2052	—	3521
	3315	2202	—	3821
	3615	2352	—	4121

ES10-10MM

mast types	Lift h3+h13 (mm)	Lowered mast height h1 (mm)	Free lift h2 (mm)	Extended mast height h4 (mm)
Duplex ZT	1605	1940	1505	1955
	1955	2290	1855	2305

ES12-12MM

mast types	Lift h3+h13 (mm)	Lowered mast height h1 (mm)	Free lift h2 (mm)	Extended mast height h4 (mm)
Duplex ZT	1605	1940	1505	1955
	1955	2290	1855	2305

ES10-22MM

mast types	Lift h3+h13 (mm)	Lowered mast height h1 (mm)	Free lift h2 (mm)	Extended mast height h4 (mm)
Duplex ZT	1560	1940	1387	2053
	1910	2290	1737	2403

ES12-25MM

mast types	Lift h3+h13 (mm)	Lowered mast height h1 (mm)	Free lift h2 (mm)	Extended mast height h4 (mm)
Duplex ZT	1560	1940	1387	2053
	1910	2290	1737	2403

ES10-22DM

mast types	Lift h3+h13 (mm)	Lowered mast height h1 (mm)	Free lift h2 (mm)	Extended mast height h4 (mm)
Duplex ZT	2470	1803	—	3395
	2670	1903	—	3595
	2970	2053	—	3895
	3270	2203	—	4195

ES12-25DM

mast types	Lift h3+h13 (mm)	Lowered mast height h1 (mm)	Free lift h2 (mm)	Extended mast height h4 (mm)
Duplex ZT	1160	1600	1110	1600
	1360	1800	1310	1800
	1560	2000	1510	2000
	1660	2100	1610	2100
	2470	1833	—	3395
	2670	1933	—	3595
	2970	2083	—	3895
	3270	2233	—	4195
	3570	2383	—	4495

Option

Options	ES10-10ES	ES12-12ES
Fork width	○685mm/600mm	○685mm/600mm
Battery capacity	○85AH/105AH /120AH	○85AH /105AH /120AH
Special backrest	—	—
Battery indicator with hour meter	○	○
Driving wheel	○PU wheel with Pattern	○PU wheel with Pattern
half speed function in turning	—	—
Mast screen	●organic glass	●organic glass
Height limitation	○	○
Note: ● standard ○ option — NA		

Options	ES10-10MM	ES12-12MM
Fork width	○685mm/600mm	○685mm/600mm
Battery capacity	●85AH	—
Special backrest	—	—
Battery indicator with hour meter	○	○
Driving wheel	○PU wheel with Pattern	○PU wheel with Pattern
half speed function in turning	—	—
Mast screen	●	●
Height limitation	—	—
Note: ● standard ○ option — NA		

Options	ES10-22DM	ES12-25DM
Fork width	—	—
Battery capacity	○85AH/105AH /120AH	○85AH /105AH /120AH
Special backrest	●	●
Battery indicator with hour meter	○	○
Driving wheel	○PU wheel with Pattern	○PU wheel with Pattern
half speed function in turning	—	—
Mast screen	●organic glass	●organic glass
Height limitation	○	○
Note: ● standard ○ option — NA		

Options	ES10-22MM	ES12-25MM
Fork width	—	—
Battery capacity	—	—
Special backrest	○	○
Battery indicator with hour meter	○	○
Driving wheel	○PU wheel with Pattern	○PU wheel with Pattern
half speed function in turning	—	—
Mast screen	●	●
Height limitation	—	—
Note: ● standard ○ option — NA		